

## **Nonlinear Response of Uniformly Loaded Paddle Cantilever Based upon Intelligent Techniques**

*Akeel Ali Wannas and Mohammed K. Abd*

*Mechanical Engineering Department, Electrical and Electronic Engineering Department,  
University of Technology, Baghdad, Iraq*

*Received on :17/3/2011*

*Accepted on : 15/10/2011*

### **ABSTRACT.**

Modeling and simulation are indispensable when dealing with complex engineering systems. It makes it possible to do essential assessment before systems are built, Cantilever, which help alleviate the need for expensive experiments and it can provide support in all stages of a project from conceptual design, through commissioning and operation. This study deals with intelligent techniques modeling method for nonlinear response of uniformly loaded paddle. Two Intelligent techniques had been used (Radial Base Function Neural Network and Support Vector Machine). Firstly, the stress distributions and the vertical displacements of the designed cantilevers were simulated using (ANSYS v12.1) a nonlinear finite element program, incremental stages of the nonlinear finite element analysis were generated by using 25 schemes of built paddle Cantilevers with different thickness and uniform distributed loads. The Paddle Cantilever model has 2 NN; NN1 has 5 input nodes representing the uniform distributed load and paddle size, length, width and thickness, 8 nodes at hidden layer and one output node representing the maximum deflection response and NN2 has inputs nodes representing maximum deflection and paddle size, length, width and thickness and one output representing sensitivity ( $\Delta R/R$ ). The result shows that of the nonlinear response based upon SVM modeling better than RBFNN on basis of time, accuracy and robustness, particularly when both has same input and output data.

**Key words: SVM, nonlinear response, cantilever, finite element, uniformly loaded, sensors.**

### **1. INTRODUCTION.**

Cantilever sensors are the most important electric machinery in all the fields of industry. Cantilever sensors are based on relatively well known and simple transduction principle a simple cantilever beam can be used as a sensor for biomedical, chemical and environmental applications. When micro-fabricated multilayered cantilever beam is exposed to sensing environment, it bends because of single or a combination of external forces like electrostatic, electric, magnetic, mass, nuclear radiation or mere mass. Similarly, it can bend because of intrinsic stresses generated due to chemical, physical or thermal means within the upper layer of cantilever itself.

As recent research efforts advance in several converging areas of science and technology, cantilever-based sensors have been proved to be quite versatile and sensitive devices and have been used mainly in the trace detection of bio-chemical materials. The cantilever method of bio-chemical sensing does not require any fluorescence tagging, therefore gets many attentions [1]. Micro machined silicon cantilever beams have been applied in fluid flow volume sensing [2; 3], Abdullh H.Abdulla [4] study the nonlinear response of paddle cantilever by using RBFNN .

In addition, the actual mechanism for detection of the cantilever deflections is also very

important. The amount of deflections of a cantilever beam can be detected by several read-out systems, including optical detection, capacitive detection, tunneling detection and interferometer detection. The optical level technique and the piezoresistive method are usually used to detect cantilever beam deflection. In general, the deflection is caused by its interaction with measured under circumstances of stress, a small force and a change of mass or temperature. However, for more complex structures, finite element modeling is useful to analyze and optimize these structures.

In this research, an original application of Support Vector Method (SVM) for nonlinear response for paddle cantilevers was proposed. The theoretical mechanical characteristic of silicon cantilever beams is represented, such as the spring constant, deflection and relative change in piezoresistivity. An optimal structure is sought by using structural analysis and numerical finite element analysis. The SVM method and most of the results from this analysis should, however, be directly applicable to other types of piezoresistive sensors, including commercially available pressure sensors and accelero-meters. Second the model is constructed through the use of the ITS designed by using MATLAB And ANSYS software.

## 2. THEORETICAL MODEL ANALYSIS.

In this study, the simple and paddle cantilever sensors as shown in **Fig. (1.2)** were modeled using the static equations of mechanics. To calculate the amount of deflection at the tip of a cantilever beam, the differential equation of a cantilever beam for a small deflection is given by [5],

$$\delta = EI \frac{d^2 y(x)}{dx^2} M \quad (1)$$

$M = Px$  when a single force  $P$  is applied on the free end of the cantilever,  $M = qx^2/2$  under a flowing fluid situation, where,  $q$  is a force element at the position  $x$  along the cantilever beam and is proportional to the surface area facing towards the flowing fluid and drag force. The drag force is proportional to the fluid density, the drag coefficient of the cantilever and the flow velocity squared in a turbulent flow or flow velocity in a laminar flow.

When, the  $x$ -axis origin is selected at the free end of the cantilever beam, the boundary conditions are given by:

$$\begin{aligned} x = L & \quad dy/dx = 0 \\ x = L & \quad y = 0 \end{aligned}$$

Now, integrate the differential equation for cantilever deflection and use the above mentioned boundary conditions [6].

$$\frac{dy(x)}{dx} = \frac{1}{EI} [Px^2/2 + k_1] \quad (2)$$

Eventually, the deflection of the cantilever beam when a single force is applied at the free end of the cantilever is given as:

$$y(x) = \frac{2P}{Ewt^3} [x^3 - 3L^2x + 2L^3] \quad (3)$$

Resistance change can be calculated using the equation:

$$\frac{\Delta R}{R} = \sigma_1 \pi_1 + \sigma_t \pi_t \quad (4)$$

In direction of P-type resistor,  $\pi_{44}$  is more dominant over the other 2 coefficients  $\pi_{11}$  and  $\pi_{12}$ . Hence, the Eq. 4 can be approximated by:

$$\frac{\Delta R}{R} = \frac{R_{44}(\sigma_1 - \sigma_t)}{2} \quad (5)$$

From the Eq. 5, the resistance change is increased by maximizing the differential stress ( $\sigma_1 - \sigma_t$ ). The relationship between the relative change of the piezoresistance and the deflection of the Simple cantilever at the free end is:

$$\frac{\Delta R}{R} = \beta \frac{3\pi EtL}{2L^3} y(0) \quad (6)$$

The relationship between the relative change of the piezoresistance and the deflection of the Paddle cantilever at the free end is:

$$\frac{\Delta R}{R} = \beta \frac{3\pi EtL}{2[L^3 - l^3 + 2wt^2]} y(0) \quad (7)$$

### 3. MATERIALS AND METHODS.

From the examples ANN captures the domain knowledge. ANN can handle continuous as well as discrete data and have good generalization capability as with fuzzy expert systems. An ANN is a computational model of the brain. They assume that computation is distributed over several simple units called neurons, which are interconnected and operate in parallel thus, known as parallel distributed processing systems or connectionist systems. Implicit knowledge is built into a neural network by training it. Several types of ANN structures and training algorithms have been proposed.

For effective predicting of paddle cantilever, the selection of proper inputs and outputs of ANN, structure of the network and training of it using appropriate data should be done with utmost care. In the present study, inputs are selected as uniform distributed load, paddle cantilever size, length, width and thickness. The NN outputs have been termed as one output node representing the maximum deflection response (1500×1 represent the deflection response of load) **Fig. (3)**.

**SVM:** Support vector machines represent an extension to nonlinear models of the generalized portrait algorithm developed by [7] The SVM algorithm is based on the statistical learning theory and the Vapnik-Chervonenkis (VC) dimension [7] .

The statistical learning theory, which describes the properties of learning machines that allow them to give reliable predictions [8] Finding an SVM model with good prediction statistics is a trial-and-error task. The objective is to maximize the predictions statistics while keeping the

model simple in terms of number of input descriptors, number of support vectors, patterns used for training and kernel complexity. A popular option is the use of SVM scripts in computing environments such as MATLAB 7.

**RBFFNN:** The basic form of RBF architecture involves entirely 3 different layers. The input layers is made n, of source nodes, while the second layer is hidden layer of high enough dimension, which senses a different purpose from that in a multilayer perception. The output layer supplies the response of the network to the activation patterns applied to the input layer. The transformation from the input layer to hidden is nonlinear whereas the transformation from the hidden from unit to the output layer is linear [4].

$$\text{radbas}(n) = e^{-n^2}$$

This function calculates a layer's output from its net input.

**Computer modeling:** The cantilever beam was modeled using ANSYS software. **Fig. (4)** is screen snapshot of how ANSYS modeled the paddle cantilever beam. Modeling begins by choosing an element type, a beam, truss element, frame, solid, shell, etc. Solid 92 was chosen as the element type because it was a 3-dimensional element and had the capability of 6° of-movement at each node point. Node locations were entered in Cartesian coordinates and these were used to construct an area and then a volume. The volume was then meshed, which fills in node points throughout the entire volume for the finite element analysis. Before a solution is run, loading of the beam, which includes both constraints and actual loads must be added. In **Fig. (4)**, the left side 2 ends of paddle cantilever of the beam were completely restrained in all degrees of freedom. A gravitational force was applied and then the solution was implemented. **Figure (4)** shows the structure in its deformed and unreformed shape after analysis. The maximum deflection of the beam occurred at the beam tip.

Using this ANSYS software, the simple and paddle cantilever were modeled for a series of structures and found the sensitivities and also compared with theoretical calculated sensitivities, this will be covered in detail in analysis and results study.

#### **4. RESULTS AND DISCUSSION.**

In piezoresistive cantilever sensors, the main device parameters are sensitivity of the device and maximum detectable measure and which is related to the maximum relative change of the resistance within the fracture strength of silicon.

ANSYS finite element software has been used as a tool to model the mechanical properties of the cantilever firstly. The analysis performed here use only the surface stress of the cantilever and the depth effects at the piezoresistive sensing regions are ignored for simplification. For the ANSYS simulation described in this paper, Young modulus of  $1.5 \times 10^{11} \text{ Nm}^{-2}$ , Poisson's ratio of 0.23 and density of  $2.23 \times 10^3 \text{ kg m}^{-3}$  for silicon are used. The finite element mesh is simplified with the element type of brick and static analysis. All the loads were applied at the end of the cantilever. The paddle cantilever in this work designed and the leg dimensions are  $300 \times 30 \mu\text{m}$  in length and width with a thickness of  $2.5 \mu\text{m}$ , while the square type paddle of  $150 \times 150 \mu\text{m}$ .

The measured relative changes of the resistance versus the deflection of the cantilevers are shown in **Fig. (5)** for the designed cantilever paddles. The symbols are the calculated results and the solid lines are the fitted results by using the derived formulae. The slopes of the lines are the sensitivities of the cantilever devices.

To train ANN models with the results above of the finite element analyses, network architecture was required; first the entire training data file was randomly divided into training and testing data sets. About 90% of the data 1350 patterns, were used to train the different network architectures where remaining 150 patterns were used for testing to verify the prediction ability of each trained NN model.

**Table (1)** the output of NN1, which shows comparison sample of maximum deflection for a set of paddle cantilever sensors has been calculated by SVM, RBFNN and FEM techniques. The Young's modulus  $E$  coefficient of silicon is taken as  $1.5 \times 10^{11} \text{ N m}^{-2}$  in our design.

From the analysis of the results in **Table (1)**, it is observed that the accuracy of the SVM and RBFNN method was slightly superior when compared to the FEM techniques on account of Mean Average Error (MAE).

**Fig. (6)** shows a plot of finite element maximum deflections compare with corresponding SVM and ANN prediction.

**Table (2)** the output of NN2, which shows comparison sample of sensitivity ( $\Delta R/R$ ) for a set of paddle cantilever sensors has been calculated by SVM, RBFNN and FEM techniques.

## 5. CONCLUSION.

In the present study, the Support Vector Machine (SVM) and Radial Basis Function (RBFNN) have been explored for predicting nonlinear response of uniformly loaded paddle cantilever. The simulation data from ANSYS software has been used for training and testing. The simulation results show that SVM can be very successively used for reduction of the effort and time required determining the load-deflection response of paddle cantilever as the FE methods usually deal with only a single problem for each run. This means that it can solve many problems that have mathematical and time difficulties. Modeling and simulation are indispensable when dealing with complex engineering systems. It makes it possible to do essential assessment before systems are built, it can alleviate the need for expensive experiments and it can provide support in all stages of a project from conceptual design, through commissioning and operation.

## 6. REFERENCES.

- [1] Lang, H.P., M.K. Baller, F.M. Battiston, J. Fritz, R. Berger, J.P. Ramseyer, P. Fornaro, E. Meyer, H.J. Güntherodt, J. Brugger, U. Drechsler, H. Rothuizen, M. Despont, P. Vettiger, Ch. Gerber and J.K. Gimzewski, "The nanomechanical NOSE", IEEE Proceedings MEMS", 99, Orlando, Florida, USA, pp. 9-13, 1999.
- [2] Vig, J.R., R.L. Filler and Y.K. Kim, "Microresonator sensor arrays, Frequency Control Symposium", 49th. Proceedings of the IEEE Int., pp. 852-869. DOI: 10.1109/FREQ.1995.484096, 1995.
- [3] Rong, Z., W.D. Qu, Z. Zhao Ying and Y.X. Ying, "Design of a Hybrid Micro/Nano Cantilever-based Resonant Sensor and its Fabrication Method Nano/Micro Engineered and Molecular Systems", NEMS. 1st IEEE Int. Conf., pp. 766-769. DOI: 10.1109/NEMS.2006.334891, 2006.
- [4] Abdullah H. Abdullah, "RBFNN Model for Predicting Nonlinear Response of Uniformly Loaded Paddle Cantilever", American Journal of Applied Sciences 6 (1), pp. 89-92, 2009.
- [5] Abadal, G., D.Z. James, H. Bjarne, X. Borrise, R. Ruiz, B. Anja, F. Campabadal, J. Esteve, E. Figueras, F. Perez-Murano and N Bamiol, "Electromechanical model of a resonating nano-cantilever-based sensor for high-resolution and high-sensitivity mass detection", Nanotechnology, 12 (2), pp. 100-104, 2001.
- [6] Timoshenko S., "Strength of Materials, Part I Elementary Theory and Problems", 3rd Edn., (Princeton, NJ: Van Nostrand), pp. 137-40.

- [7] Vapnik, V. and A. Lerner, "Pattern Recognition Using Generalized Portrait Method", Automation and Remote Control, 24, pp. 774-780, 1963.
- [8] Cui, J., Z. Li, J. Gao, R. Lv and X. Xu, "The Application of Support Vector Machine in Pattern Recognition", IEEE Int. Conf. Control Automation (ICCA), pp. 3135-3138. DOI: 10.1109/ICCA.2007.4376939, 2007.
- [9] Yu, X.M., H. Ole and B. Anja, "Optimization of sensitivity and noise in piezoresistive cantilevers", J. Applied Phys., 92 (10), pp. 6296-6301, 2002.

### 7. NOMENCLATURE.

ANN	Artificial neural network.
E	Young's modulus
I	The area moment of the cross section with respect to the neutral axis of the cantilever.
l, L, w, t	the paddle size, length, width and thickness of the cantilever paddle, respectively.
$k_1$	Integration constant.
M	The bending moment.
$\Delta R, R$	The resistance and it's the change under the strain.
y (x)	: The deflection along the cantilever beam.
$\beta$	A correction factor, which allows for the position of the resistors on the cantilever.
$\delta$	Deflection of cantilever beam.
$\sigma_l$ and $\sigma_t$	longitudinal and transverse stress components.
$\pi_l$ and $\pi_t$	longitudinal and transverse piezoresistance coefficients.

**Table (1):** Output NN1 Max. deflection for a set of paddle cantilever sensors and dimensions ( $10^{-6}$  m).

L	l	t	w	Ksp (Nm <sup>-1</sup> )	Vertical deflection FEM	Vertical deflection RBFNN	Vertical deflection SVM	Discrepancy% SVM	Discrepancy% RBFNN
200	100	2.5	25	1.8310	5.822	5.933	5.875	0.009103	0.019066
250	100	2.5	25	0.9380	3.721	3.848	3.798	0.020693	0.034131
300	100	2.5	25	0.5425	2.562	2.695	2.546	-0.00625	0.051913
350	100	2.5	25	0.3417	1.926	1.993	1.965	0.020249	0.034787
300	150	2.5	30	0.6510	2.599	2.695	2.658	0.022701	0.036937
350	150	2.5	30	0.4100	1.901	1.993	1.954	0.02788	0.048396
400	150	2.5	30	0.2747	1.492	1.533	1.487	-0.00335	0.02748
450	150	2.5	30	0.1929	1.197	1.215	1.173	-0.02005	0.015038
400	200	2.5	40	0.3662	1.487	1.533	1.518	0.020847	0.030935
450	200	2.5	40	0.2572	1.197	1.215	1.182	-0.01253	0.015038
500	200	2.5	40	0.1875	1.001	0.987	1.001	0	-0.01399
550	100	2.5	40	0.1409	0.795	0.818	0.785	-0.01258	0.028931
AME								0.00556	0.027389
Max. Discrepancy%								0.020693	0.051913

**Table( 2 ):** Output NN2 sensitivity ( $\Delta R/R$ ) for a set of paddle cantilever sensors.

L	l	t	w	Output NN1 10-6 m	FEM	RBFNN	SVM	Discrepancy% SVM	Discrepancy% RBFNN
200	100	2.5	25	From Table 1	6.63	6.75	6.676	0.00693816	0.018099548
250	100	2.5	25		4.12	4.18	4.142	0.005339806	0.014563107
300	100	2.5	25		2.72	2.87	2.656	-0.023529412	0.055147059
350	100	2.5	25		1.98	2.09	1.885	-0.047979798	0.055555556
300	150	2.5	30		2.97	3.04	2.938	-0.010774411	0.023569024
350	150	2.5	30		2.12	2.17	2.149	0.013679245	0.023584906
400	150	2.5	30		1.58	1.63	1.618	0.024050633	0.03164557
450	150	2.5	30		1.21	1.28	1.232	0.018181818	0.05785124
400	200	2.5	40		1.63	1.71	1.658	0.017177914	0.049079755
450	200	2.5	40		1.28	1.32	1.265	-0.01171875	0.03125
500	200	2.5	40		0.987	1.05	0.995	0.00810537	0.063829787
550	100	2.5	40		0.79	0.86	0.778	-0.015189873	0.088607595
AME								-0.001309942	0.042731929
Max. Discrepancy%								-0.047979798	0.055147059

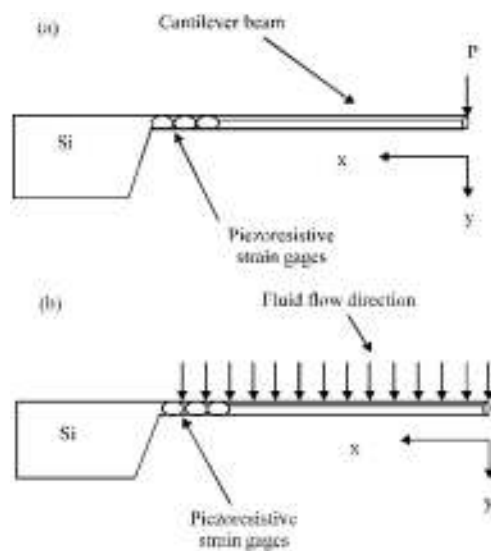

**Figure (1):** Simple cantilever, **(a)** Single force applied at the free end and **(b)** Uniformly distribute force a long the beam.

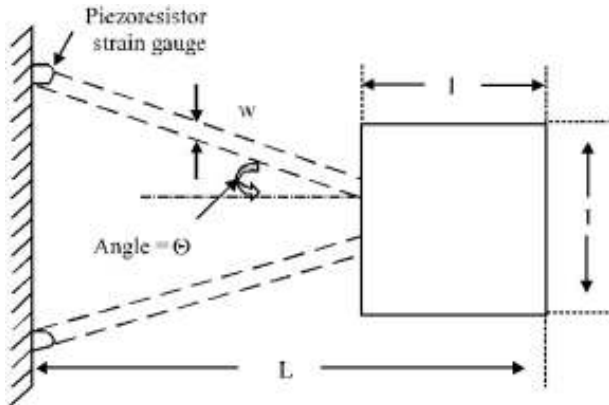

Figure (2): Paddle cantilever.

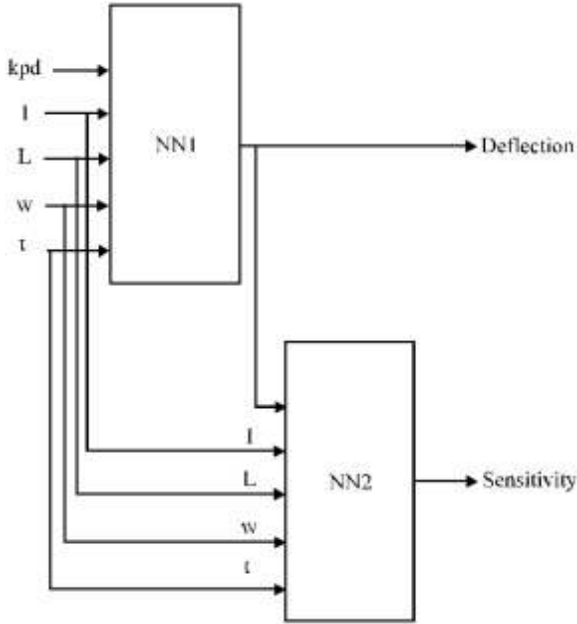

Figure (3): NN for paddle cantilever.



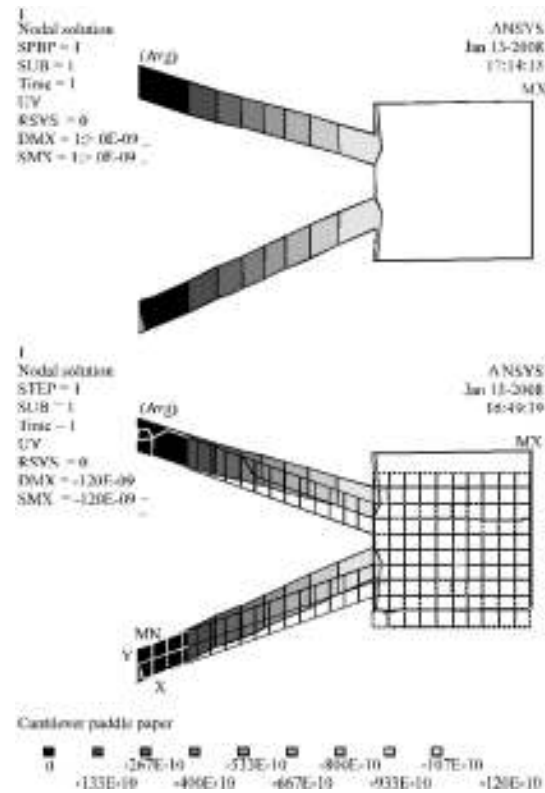
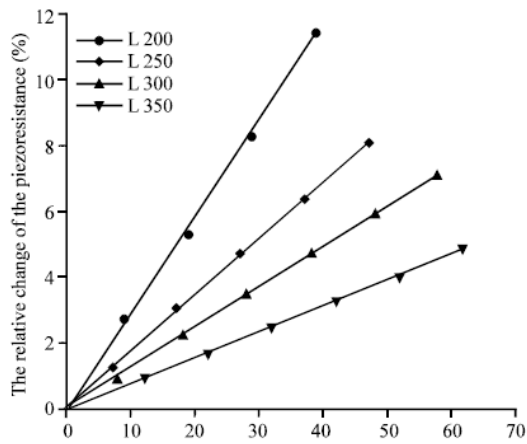
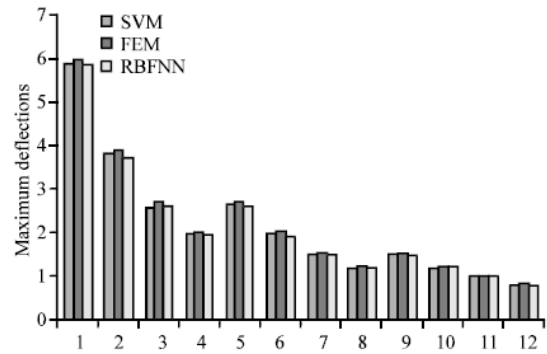

Figure (4): The structure in its deformed and unreformed shape after analysis.



Figure(5): The relative change of the resistance versus the deflection of the cantilever paddles (  $l=100$ ,  $w=25$ ,  $t=2.5 \mu\text{m}$ ).



Figure(6): Maximum deflections by finite element compare with corresponding SVM and RBFNN prediction.

## الاستجابة الغير خطية لدواسة كابولية محملة بشكل منتظم بناءا على التقنيات الحديثة

عقيل علي وناس و محمد خضر عبد

قسم هندسة المكنان والمعدات ، قسم الهندسة الكهربائية والالكترونية  
الجامعة التكنولوجية

### الخلاصة

النمذجة والمحاكاة ، لا غنى عنهما عند التعامل مع النظم الهندسية المعقدة، الذي يجعل من الممكن القيام بتقييم أساسي قبل أن يتم بناء النظام الكابولي، التي يمكن أن تساعد على تقليل الحاجة لاجراء تجارب مكلفة، توفر الدعم في جميع مراحل المشروع من التصميم النظري. تتناول هذه الدراسة طريقة ذكية لتقنيات النمذجة للاستجابة الغير خطية لدواسة محملة بشكل منتظم. وقد استخدمت تقنيتين ذكيتين دالة القاعدة الشعاعية للشبكات العصبية (RBFNN)، وآلة دعم المتجه (SVM). وقد تم حساب الاجهادات والتشوهات العمودية باستخدام برنامج ANSYS ، تم إنشاء مراحل إضافية للتحليل استخدمت فيها 25 مخطط لدواسة كابولية بواسطة طريقة العناصر المحددة الغير خطية لتغير السمك والحمل المنتظم، نماذج الدواسة الكابولية اثنان NN1, NN تمتلك خمس مدخلات تمثل الحمل المنتظم والحجم والطول والعرض والسمك وثمان عقد في طبقة مخفية ومخرج واحد يمثل استجابة أقصى تشوه و NN2 تمتلك المداخلات التشوه الاقصى وحجم الدواسة والعرض والطول والسمك ومخرج واحد يمثل الحساسية . تظهر النتائج ان الاستجابة الغير خطية اعتماداً على النمذجة بواسطة SVM هي افضل من النمذجة بواسطة RBFNN .

كلمات رئيسية : الاجهادات ، التشوه ، النمذجة بواسطة SVM ، النمذجة بواسطة RBFNN ، الاستجابة غير الخطية ، طريقة العناصر المحددة .